



Installation and operating instructions

AUL 05.4 - Stainless steel wall- with rounded inner corners, 2995 mm

Basic technical information

Inner dimensions of the sink: 2995 x 330 x 200 mm
Diameter of the outlet: 52 mm (with pressed edge for 6/4" sink siphon)
Weblink: [AUL 05.4](#)

Description of the stainless steel trough

- AUL 05.4 is a stainless steel wall-mounted trough with rounded inner corners. Its construction enables installation of outflow arms, or sensor-controlled taps. The standard version of the trough is without openings for the taps. Version type of the trough is left or right – as per the location of water outlet (from a front view).

Installation

Requirements for setting up construction

- Set-up the outlet. Its size and location depends on the chosen siphon. Centre line of the outlet is 60 mm from the chosen edge.

Assembly of the trough

- Set up the carrying bar on the wall with anchoring bolts into the joggles. Bolts and joggles supplied by producer enable fixing into the sufficiently bearing masonry wall (solid brick or concrete wall, etc.). For fixing into the other walls (cavity brick wall, etc.) it is necessary to use suitable anchoring material.
- Fix the trough properly on the carrying bar.
- Fix both sides of the trough with anchoring bolts into the joggles..
- Set-up siphon.
- Seal the gap between the trough and the wall with suitable gap-filling glue to prevent water leaking.

Complete delivery

- Stainless steel trough 1 pc.
- Anchoring bolts, joggles and washers 7 pcs.
- Siphon is not included in delivery.**

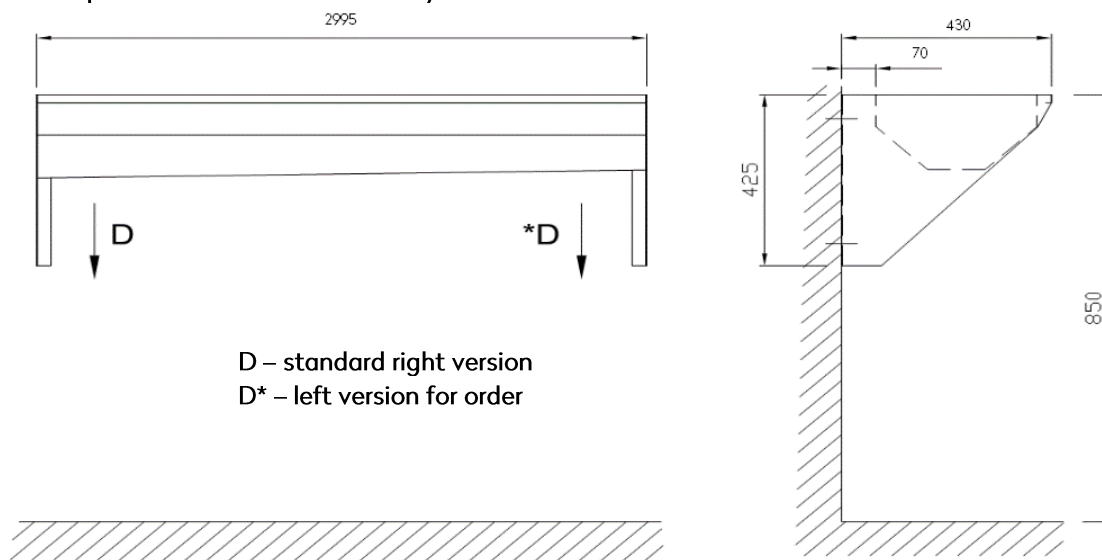



Maintenance and cleaning

- The device was made from the stainless steel of quality corresponding with ČSN 17 240 (AISI 304) standard (other materials, e.g. AISI 316, made to order) and, therefore, it must not be operated in chemically-aggressive environment and
- **Preparations containing chlorine must not be used for its cleaning!!**
- Cleaning agents by WÜRTH are recommended:
 - Metal renewal agent - Order No. 893 121 1
 - Stainless steel spray treatment - Order No. 0893 121 – K.
- When used in the same surrounding in which standard steel is processed, superficial corrosion can appear due to the sediments of metal particles on the bottom of the trough. It is necessary to rinse well the trough after every usage to remove this possible deposits of corrosion.